

Compact Waterproof Automotive In-line Connector

CONNECTOR

MX80 Series

MB-0354-2

March 2020

RoHS Compliant

The MX80 Series is a compact waterproof automotive in-line connector. It is a miniaturized connector ideal for use in areas where vehicle mounting space is limited. It is waterproof and dust resistant under IP67 guidelines.

Applicable Market Segments

•Automotive applications such as side view mirrors, vehicle license plate lighting, etc.

Features

- ISO/JASO standard 0.64 mm tab size
- Terminal Position Assurance on pin and socket housing
- Follows USCAR-2
- IP67 waterproof rating
- Compatible with 2.54mm pitch pin contacts
- Integrated bracket supports chassis fastening vehicle clips

General Specifications

Number of Contacts	3 positions
Operating Temperature Range	-40°C~ +125°C
Contact Pitch	2.54mm
Applicable Wire	0.3~0.5mm ² (Example cable types: FLRY-A, FLRY-B, AESSX, etc.)
Rated Current	3.7A, when 0.35 mm ² wire is used (Ambient temperature: 105°C)
	4.5A, when 0.5 mm ² wire is used (Ambient temperature: 105°C)
Dielectric Withstanding Voltage	AC500V (1 minute)

Current value is different for each operating temperature. Please contact us for details.

Features

In-line Pin Connector

Socket Connector

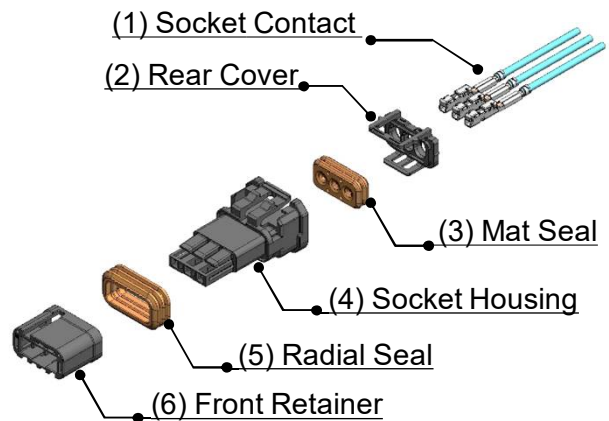
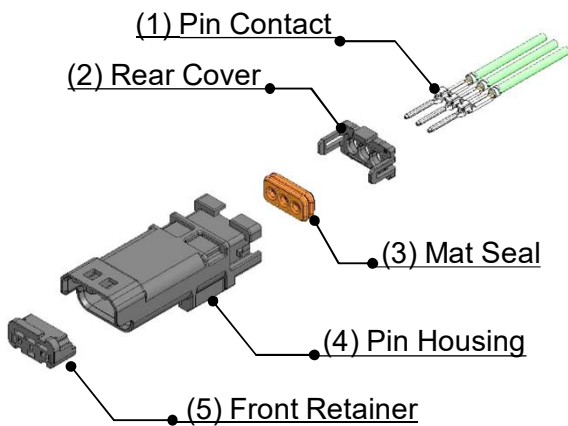
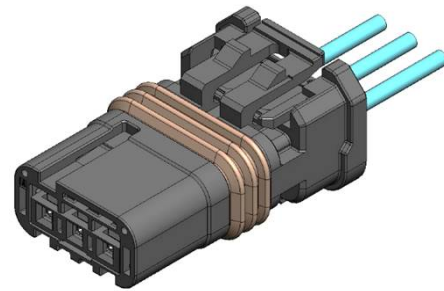
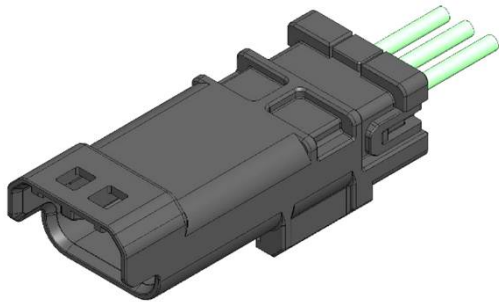

Component	Material
(1) Pin Contact	Copper alloy / Tin plating
(2) Rear Cover	PBT-GF10
(3) Mat Seal	Silicone Rubber
(4) Pin Housing	PBT-GF10
(5) Front Retainer	PBT-GF10

Component	Material
(1) Socket Contact	Copper alloy / Tin plating
(2) Rear Cover	PBT-GF10
(3) Mat Seal	Silicone Rubber
(4) Pin Housing	PBT-GF10
(5) Radial Seal	Silicone Rubber
(6) Front Retainer	PBT-GF10

Dimensions (Unmated)

Basic Dimensions All units in mm

In-line Pin Connector

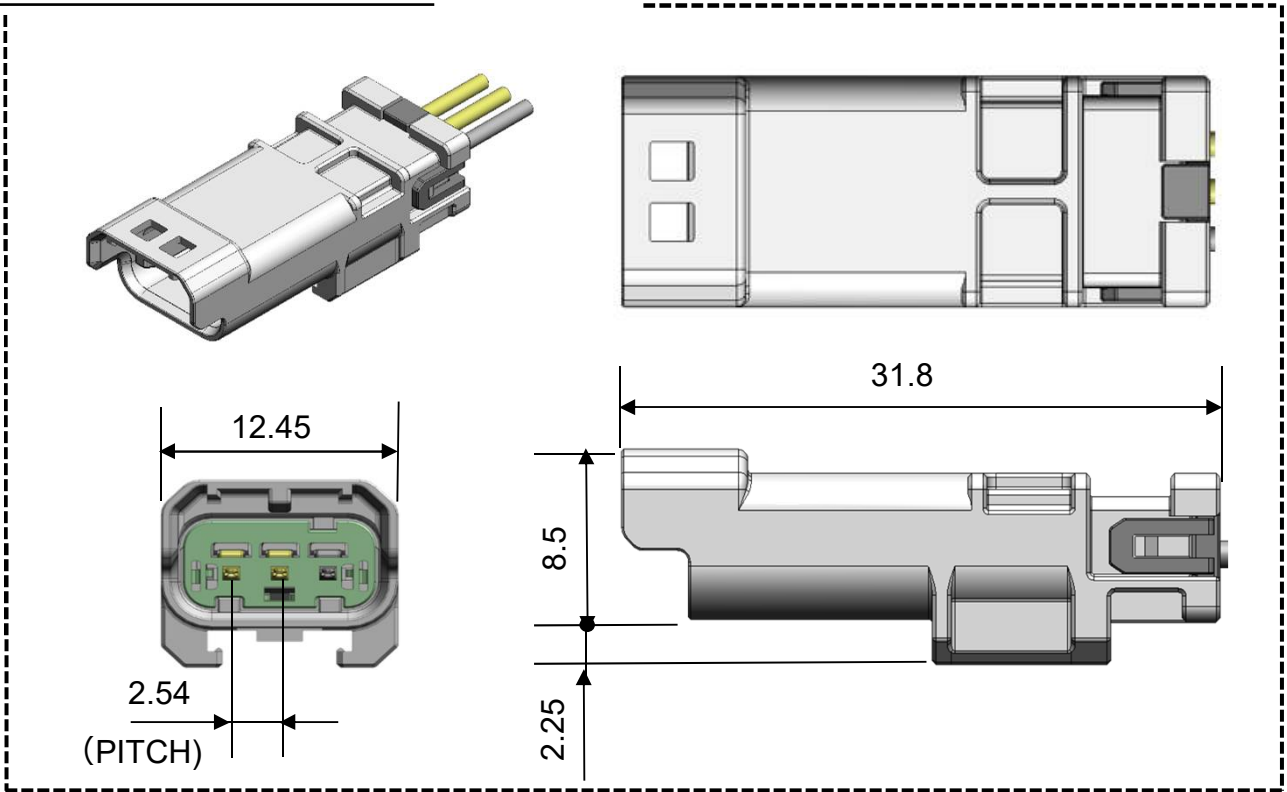

Socket Connector

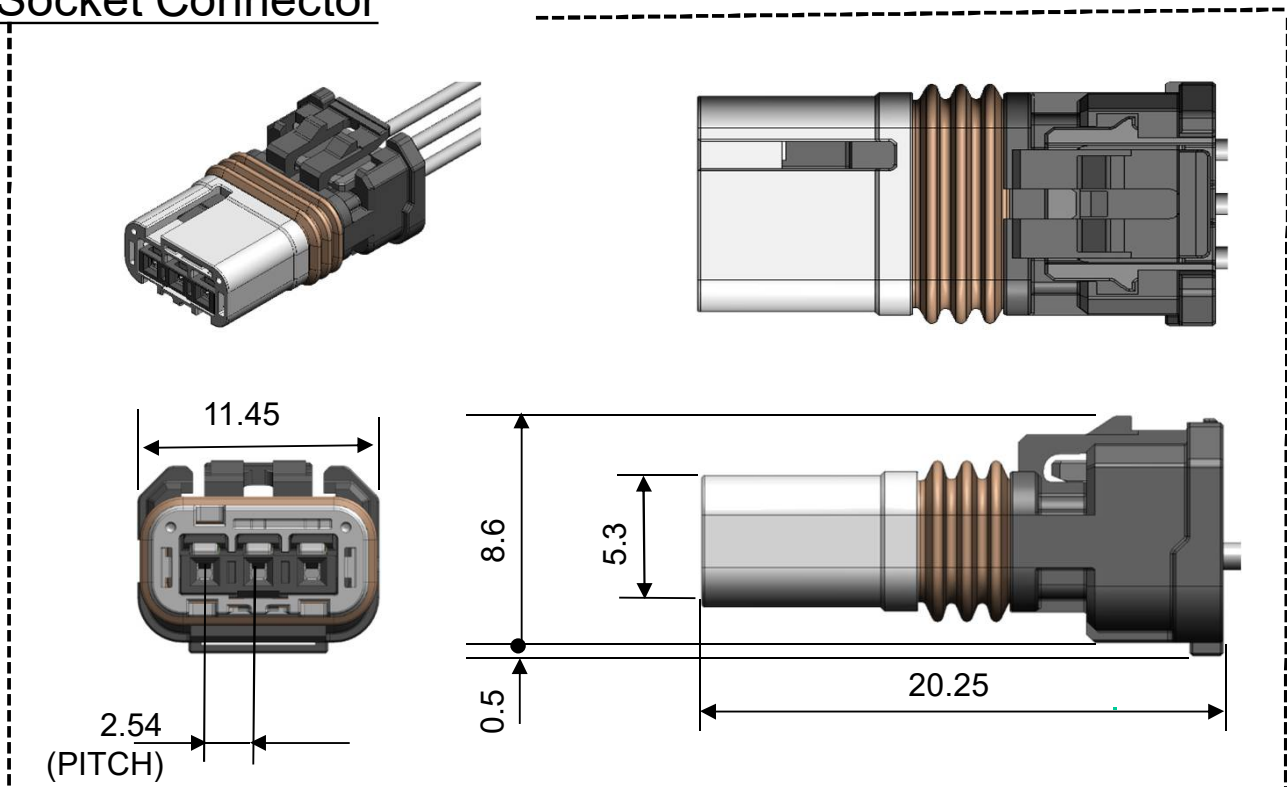

Dimensions (When mated)

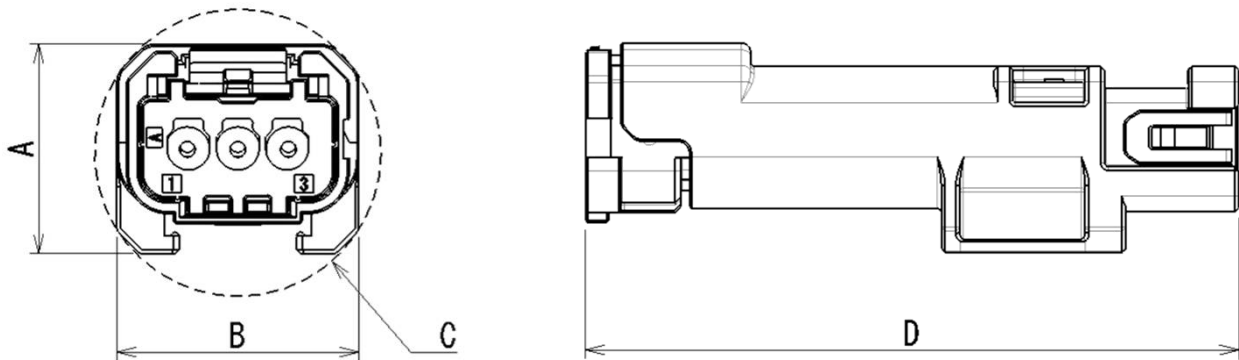

Number of Contacts	Dimensions [mm]			
	A	B	C (Note)	D
3 position	10.75	12.45	∅ 14.75	33.6

Note)

The above dimensions are the target value for a circumscribed circle size. Please note that the connector through-hole size is ∅ 16.75mm.

Technical Documents

	Part Number	Drawing Number
In-line Pin Connector	MX80B03PZ1A	SJ121228
Socket Connector	MX80A03SZ1A	SJ121229
Pin Contact	MX80P10K4F1	SJ121374
Socket Contact	MX80S08K4F1	SJ121372

Note) We are planning to expand the MX80 Series product lineup by adding additional variations such as pin count variations. Please contact us for further information.

Notice:

1. The values specified in this brochure are only for reference. The products and their specifications are subject to change without notice. Contact our sales staff for further information before considering or ordering any of our products. For purchase, a product specification must be agreed upon.
2. Users are requested to provide protection circuits and redundancy circuits to ensure safety of the equipment, and sufficiently review the suitability of JAE's products to the equipment.
3. The products presented in this brochure are designed for the uses recommended below. We strongly suggest you contact our sales staff when considering use of any of the products in any other way than the recommended applications or for a specific use that requires an extremely high reliability.
 - (1) Applications that require consultation:
 - (i) Please contact us if you are considering use involving a quality assurance program that you specify or that is peculiar to the industry, such as:
Automotive electrical components, train control, telecommunications devices (mainline), traffic light control, electric power, combustion control, fire prevention or security systems, disaster prevention equipment, etc.
 - (ii) We may separately give you our support with a quality assurance program that you specify, when you think of a use such as :
Aviation or space equipment, submarine repeaters, nuclear power control systems, medical equipment for life support, etc.
 - (2) Recommended applications include:
Computers, office appliances, telecommunications devices (terminals, mobile units), measuring equipment, audiovisual equipment, home electric appliances, factory automation equipment, etc.

Japan Aviation Electronics Industry, Limited

Product Marketing Division
 Aobadai Building, 3-1-19, Aobadai, Meguro-ku, Tokyo 153-8539
 Phone: +81-3-3780-2882 FAX: +81-3-3780-2946

* The specifications in this brochure are subject to change without notice. Please contact JAE for information.